

Mathematics Contest Spring 2005
Solutions and Answers

Multiple Choice Questions

1. George's company was losing money, as a result George received a 25% pay cut. By what percentage must his new pay rate be raised to bring it back to the original level?

- a. 25% b. 50% c. 100% d. $33\frac{1}{3}\%$ e. 40%

SOLUTION: Let x be his old pay rate and y his new pay rate, then

$$y = \frac{3}{4}x \text{ so } x = \frac{4}{3}y$$

2. Let $\#$ be the binary operation on the set of positive real numbers that satisfies the following: $(xy^2) \# y = x(y \# 1)$ and $(x \# 1) \# x = 1$

If $1 \# 1 = 1$, then what is $x \# y$?

- a. xy b. $\frac{y}{x}$ c. $\frac{x}{y}$ d. x^2y e. xy^2

SOLUTION: With $x=a$ and $y=1$ we get $(a\#1) = (a \cdot 1^2) \# 1 = a(1\#1) = a$

$$\text{So } (x\#y) = \left(\frac{x}{y^2}y^2\right) \# y = \frac{x}{y^2}(y\#1) = \frac{x}{y^2}y = \frac{x}{y}$$

3. The value of $\sqrt{16+\sqrt{16+\sqrt{16+\dots}}}$ is

- a. $2\sqrt{2}$ b. 4 c. 4.52 d. 8 e. $\frac{1}{2} + \frac{\sqrt{65}}{2}$

SOLUTION: Let $A = \sqrt{16+\sqrt{16+\sqrt{16+\dots}}}$ then $A^2 = 16 + A$. Use quadratic formula to solve for A

4. If $x + y + z = 0$, then $x^3 + y^3 + z^3$ equals

- a. 0 **b. $3xyz$** c. $-3x^2y$ d. $3xy^2$ e. none of the above

SOLUTION: $x^3 + y^3 + z^3 = x^3 + y^3 + (-x-y)^3 = -3x^2y - 3xy^2 = 3xy(-x-y) = 3xyz$

5. If $\log_4(\log_4(\log_4(\log_4(x)))) = 0$, what is the value of x ?

- a. 256^3 b. 4^{16} **c. 2^{512}** d. 256^4 e. none of the above

SOLUTION: $x = 4^{(4^{(4^{(4^0)}))})} = 4^{256} = 2^{512}$

6. The base of a regular pyramid is a square with side length 10 meters. If the total surface area of the four triangular sides of the pyramid (not including the base) is 320 square meters, what is the height of the pyramid?

- a. $2\sqrt{39}$ **b. $\sqrt{231}$** c. 16 d. 32 e. none of the above

SOLUTION: Each slanted triangle has area $= \frac{1}{4} 320 = 80$ and base 10 so altitude = 16. Thus a vertical cross section of the pyramid is an isosceles triangle with base 10 and side 16. Therefore the altitude $= \sqrt{16^2 - 5^2} = \sqrt{231}$

7. A triangle has side $a = \sqrt{7}$, the opposite angle $\alpha = 60^\circ$, and the sum of the two other sides is $b + c = 5$. Find the ratio of the longest to the shortest side of the triangle.

- a. 1 b. $\sqrt{2}$ **c. $\frac{3}{2}$** d. $\frac{\sqrt{7}}{2}$ e. 2

SOLUTION: $a^2 = b^2 + c^2 - 2bc \cos 60^\circ$; $7 = b^2 + c^2 - bc = b^2 + (5-b)^2 + b(5-b)$
So $b^2 - 5b + 6 = 0$ and $b = 2$ or 3

8. What is the value of $\log_2(7^{-\log_7 0.125})$?

a. 3

b. -3

c. $\frac{1}{3}$

d. 0.125

e. 8

SOLUTION: $\log_2(7^{-\log_7 0.125}) = \log_2 \frac{1}{0.125} = \log_2 8 = 3$

9. A person starting with \$256 makes 8 bets and wins exactly four times. The wins and losses occur in random order. If each wager is for half the money she has at the time of the bet, then the final result is

a. a loss of \$81

b. a gain of \$81

c. a loss of \$175

d. neither a loss nor a gain

e. a gain or a loss depending on the order in which the wins and losses occur.

SOLUTION: After a loss, a person has $\frac{1}{2}$ as much as before, after a win, a person has $\frac{3}{2}$ as much. After 4 wins and 4 losses, a person has $256(\frac{3}{2})^4(\frac{1}{2})^4 = \81 , so that person lost $256 - 81 = \$175$.

10. A six sided die has faces labeled 1 through 6. It is weighted so that a three is three times as likely to be rolled as a one; a three and a six are equally likely; and a one, a two, a four, and a five are equally likely. What is the probability of rolling a three?

a. $\frac{1}{6}$

b. $\frac{1}{3}$

c. $\frac{2}{3}$

d. $\frac{3}{10}$

e. $\frac{2}{5}$

SOLUTION: Let $Pr(k)$ be the probability of rolling a k , and $p = Pr(1)$

$$\sum_{k=1}^6 Pr(k) = p + p + 3p + p + p + 3p = 10p = 1, \text{ so } p = \frac{1}{10} \text{ and } Pr(3) = \frac{3}{10}$$

11. What is the area of a triangle with sides 7, 8 and 9?

a. $12\sqrt{5}$

b. 31.5

c. 35

d. $18\sqrt{3}$

e. cannot be determined

SOLUTION: Let $2s = 7 + 8 + 9 = 24$. By Heron's formula

$$A = \sqrt{12(12-7)(12-8)(12-9)} = \sqrt{12 \cdot 5 \cdot 4 \cdot 3} = 12\sqrt{5}$$

12. Thirty-six students took the ACT, with a mean score of 25.5. The boys had a mean score of 23.5, while the girls had a mean score of 28. How many girls were in the group?

- a. 20 b. 18 **c. 16** d. 14 e. can not be determined.

SOLUTION: Assume b boys and g girls took the ACT, then

$$\frac{b}{b+g} 23.5 + \frac{g}{b+g} 28 = 25.5 \text{ and } b+g = 36. \quad \text{So } g=16$$

13. If m and n are natural numbers and $4m-5n=1$, what is the greatest common divisor of m and n ?

- a. 4 b. 5 c. 20 **d. 1** e. cannot be determined.

SOLUTION: Let $g = \gcd(m,n)$, then $g \mid 4m-5n=1$ so $g=1$

14 Assume that a computation using method A takes $8n^2$ seconds, where n is a natural number and represents the size of the input. Assume that method B performs the same computation in $64n \log_2 n$ seconds. Which is the largest interval for n where A performs faster than B ?

- a. $n \geq 44$ b. $n \geq 32$ **c. $2 \leq n \leq 43$** d. $2 \leq n \leq 64$ e. $1 \leq n \leq 32$

SOLUTION: Solve $8n^2 < 64n \log_2 n$ or $n < 8 \log_2 n$: by a binary search

n	1	2	4	8	16	32	64	43	44
$8 \log_2 n$	0	8	16	24	32	40	48	43.4	43.7

15. Suppose that two circles C_1 and C_2 in the plane have no points in common. Then

a. there is exactly one line tangent to both C_1 and C_2 .

b. there are exactly two lines tangent to both C_1 and C_2 .

c. there are exactly three lines tangent to both C_1 and C_2 .

d. there are no lines tangent to both C_1 and C_2 or there are exactly two lines tangent to both C_1 and C_2 .

e. there are no lines tangent to both C_1 and C_2 or there are exactly four lines tangent to both C_1 and C_2 .

SOLUTION: *There are two possibilities:*

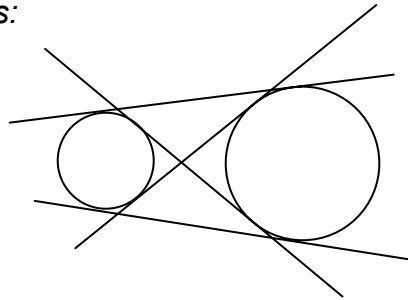
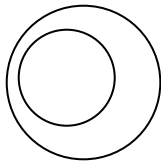

16. Convert the base four numeral 123.12 to a base five numeral.

a. $102.141414\dots$

b. $102.414141\dots$

c. $102.122222\dots$

d. $102.121212\dots$

e. none of these.

SOLUTION:

$$123.12_4 = 16 + 2 \cdot 4 + 3 + \frac{1}{4} + \frac{2}{16} = 27 + \frac{3}{8} = 1 \cdot 25 + 0 \cdot 5 + 2 \cdot 1 + \frac{1}{5} + \frac{4}{25} + \frac{1}{125} + \dots$$

17. If $f(x)$ is an invertible function, and $g(x) = 2f(x) + 5$, then what is $g^{-1}(x)$?

a. $2f^{-1}(x) + 5$

b. $2f^{-1}(x) - 5$

c. $\frac{1}{2f^{-1}(x) + 5}$

d. $\frac{1}{2}f^{-1}(x) + 5$

e. $f^{-1}\left(\frac{x-5}{2}\right)$

SOLUTION: Let $y = g^{-1}(x)$ so $x = g(y) = 2f(y) + 5$

solve for $f(y) = \frac{x-5}{2}$ and $y = f^{-1}\left(\frac{x-5}{2}\right)$

18 A parallelogram has vertices $(0,0)$, $(1, \sqrt{3})$, $(4,0)$. A fourth vertex and the area are given by

a. $(5, \sqrt{3})$ and $4\sqrt{3}$

b. $(5, \sqrt{3})$ and $5\sqrt{3}$

c. $(4, \sqrt{3})$ and 10

d. $(4,1)$ and $5\sqrt{3}$

e. $(16,3)$ and 8

SOLUTION:

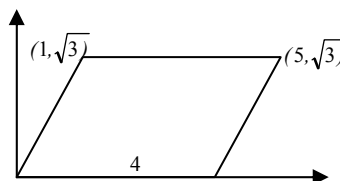

19. If 7 distinct fair 6-sided dice are rolled at the same time, what is the probability that the sum will be 10?

a. $\frac{7}{279936}$

b. $\frac{7}{23328}$

c. $\frac{1}{139968}$

d. $\frac{1}{11664}$

e. none of these

SOLUTION: $\{1,1,1,1,1,1,4\}$ can occur 7 ways; $\{1,1,1,1,1,2,3\}$ can occur $7 \cdot 6$ ways

$\{1,1,1,1,2,2,2\}$ can occur $\binom{7}{3} = 35$ ways

So the total probability is $\frac{7 + 42 + 35}{6^7}$

20. If the letters $a, A, b, B, c,$ and C are arranged at random in a row, what is the probability that the lower case letters appear in increasing alphabetical order?

a. $\frac{1}{6}$

b. $\frac{1}{2}$

c. $\frac{1}{720}$

d. $\frac{1}{36}$

e. $\frac{1}{30}$

SOLUTION: There are 6 possible arrangements of a,b,c and only one of them is in alphabetical order.

Mathematics Contest Spring 2005

Solutions and **Answers**

Integer Answer Questions

1. Suppose that the coordinates of A and D are $(1,5)$ and $(1,10)$ respectively and that $ABCD$ forms a square with the x coordinate of B greater than 1. If F has coordinates $(10,0)$ what is the area of the triangle BFC ?

SOLUTION: **10**

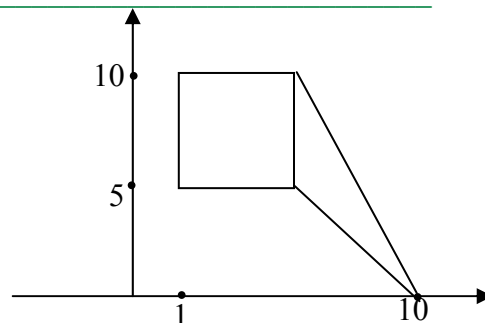

2. How many subsets of $\{n \mid 0 < n < 150 \text{ and } n \text{ is a multiple of } 4\}$ are also subsets of $\{n \mid 0 < n < 150 \text{ and } n \text{ is a multiple of } 6\}$?

SOLUTION: 12 positive integers less than 150 are multiples of 4 and 6 (and so of 12). Thus there are $2^{12} = \mathbf{4096}$ subsets

3. Suppose a rectangle has area 3 and a diagonal of length $\sqrt{10}$. What is its perimeter?

SOLUTION: Let x and y be the sides of the rectangle. Then $xy = 3$ and $x^2 + y^2 = 10$. Thus $(x+y)^2 = x^2 + 2xy + y^2 = 16$ and the perimeter $= 2(x+y) = \mathbf{8}$

4. Several people started with \$400 each, and played a game with the following unusual rules. Each player pays \$10 to the house at the beginning of each round. During each round, one active player is declared the loser, and he distributes all of his money in equal amounts to the remaining players. The loser must then leave, but all of the other players go on to the next round. The game is over as soon as only one player remains. At the end of the game, the surviving player was surprised to discover that he had exactly \$400, equaling his starting amount. How many players were there at the beginning?

SOLUTION: The players start with a total of $\$400n$. The total payments to the house are $10 \sum_{i=2}^n \left(\frac{n(n+1)}{2}\right)^{-10}$. At the end of the game, the remaining player has \$400. Solve $n 400 - 400 = 10 \left(\frac{n(n+1)}{2}\right)^{-10}$ to get $n = \mathbf{78}$

5. The driving distance from NCSSM in Durham to Disney World is 638 miles. The price of gasoline is \$1.93 per gallon. How much would the gasoline cost - to the nearest dollar – for a round trip in a car that gets 24 miles per gallon

SOLUTION: $\text{round}\left[\frac{1.93}{24} * 2 * 638\right] = \text{round}[102.6117] = \boxed{103}$

6. How many four-digit positive integers divisible by 7 have the property that, when the first and last digits are interchanged, the result is a (not necessarily four digit) positive integer divisible by 7?

SOLUTION: If $7 \mid axyb$ (where $axyb$ is the 4 digit number with digits a, x, y & b) and $7 \mid bxya$ then $7 \mid \{(a-b)1000+(b-a)\} = (a-b)999$. Since 7 does not divide 999, we must have $7 \mid (a-b)$. Since $7 \mid 1001$, all numbers of the form $axyb$ with $7 \mid xy$ are divisible by 7. Thus there are $9 \cdot 15$ possibilities from the 9 values of a and 15 possible xy . In addition, if $7 \mid xy$ then 7 divides $7xy0, 8xy1, 1xy8, 9xy2,$ and $2xy9$. These yield another $5 \cdot 15$ possibilities. So all together there are $(9+5)15 = \boxed{210}$ possibilities

7. Two numbers are called “approximately equal” if their difference is at most 1. How many different ways are there to write 2005 as a sum of one or more positive integers which are all “approximately equal” to each other? The order of terms does not matter: two ways which only differ in the order of terms are not considered different.

SOLUTION: If 2005 is a sum of k approximately equal integers, then each pair of summands can differ by at most one and so are of the form $\left[\frac{2005}{k}\right]$ or $\left[\frac{2005}{k}\right] + 1$. Thus for each $k = 1 \dots 2005$, there is only one way to write 2005 as a sum of k approximately equal integers. So all together, there are exactly $\boxed{2005}$ ways.

8. Find the radius of a circle inscribed in a triangle with sides 12, 35, and 37.

SOLUTION: Since $12^2 + 35^2 = 37^2$ the triangle is a right triangle. The area of the large triangle = the area of the three small triangles with height r = radius of the inscribed circle. So $\frac{1}{2}12 \cdot 35 = \frac{1}{2}r(12 + 35 + 37)$. Solve to get $r = 5$

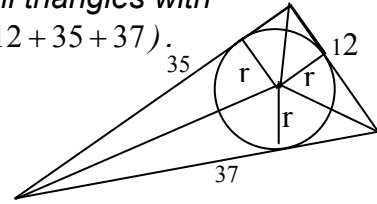

9. Find the sum of all values of k for which $2x^3 - 9x^2 + 12x - k = 0$ has a double root.

SOLUTION: If $(x-a)^2(2x-b) = 2x^3 - 9x^2 + 12x - k$ then $4a+b=9$ and $2ab+2a^2=12$. The solutions are $a=1$ and $b=5$ or $a=2$ and $b=1$. Thus $k=a^2b$ is 5 or 4 and the sum of possible values of k is 9

10. How many real numbers t are there, so that the polynomial $x^{10} + tx + 1 = 0$ has a real solution r and also has $1/r$ as a solution?

SOLUTION: Assume $r^{10} + 1 = -tr$ and $r^{-10} + 1 = -tr^{-1}$. Multiply the second equation by r^{10} to get $1 + r^{10} = -tr^9$. This implies that $tr = tr^9$. Since t and r cannot be 0, $r = 1$ or -1 are the only possible solutions. So there are 2 real numbers t that satisfy the hypotheses.

11. Let a_1, a_2, a_3, \dots be a sequence of integers satisfying $a_{n-1} + a_n = 3n$ for all $n \geq 2$. If $a_1 = 100$, find a_{1000} .

SOLUTION: $a_{2n} = -a_{2n-1} + 3(2n) = a_{2n-2} - 3(2n-1) + 3(2n) = a_{2n-2} + 3 = a_2 + 3*(n-1)$. Thus $a_{1000} = a_2 + 3*499 = 6 - 100 + 3*499 = 1403$

12. Suppose n is a positive integer with the property that there are exactly eight different positive integers m such that $\frac{n}{m}$ is an integer. If one of these eight numbers is $m = 75$ what is the largest possible value of n ?

SOLUTION: An integer n with exactly 8 factors is of the form abc , a^3b , or a^7 for distinct primes a, b , and c . Since $75 = 5^2 \cdot 3$ divides n , $n = 5^3 \cdot 3 = 375$

13. Find the smallest positive integer m such that m is not a square, but in the decimal expansion of \sqrt{m} the decimal point is followed by at least four consecutive zeros. What is the integer part of \sqrt{m} for this value of m ?

SOLUTION: Let $\sqrt{m} = a+x$ where a is the integer part of \sqrt{m} and $0 < x < 10^{-4}$.
 $m = (a+x)^2 = a^2+2ax+x^2$, m and a^2 are integers, a and x are positive. Thus $2ax+x^2$ must be a positive integer and so
 $2ax \geq 1 - x^2$; $2a \geq \frac{1}{x} - x \geq 10000 - 0.0001$; $a \geq 5000 - 0.00005$
 Since a is an integer, $a \geq 5000$
 Letting $a=5000$, we have $m=(a+x)^2 > a^2$, so the smallest m can be is a^2+1 and
 $\sqrt{m} \cong 5000.00009999999990000$. the integer part of \sqrt{m} is $\boxed{5000}$

14. Let f be the function defined by $f(x,y,z) = (x + y + z)(xy + xz + yz)/(xyz)$ for all positive real numbers $x, y,$ and z . What is the smallest possible value of f ?

SOLUTION:

$$f(x,y,z) = \frac{(x+y+z)(xy+yz+xz)}{xyz} = (x+y+z)\left(\frac{1}{x} + \frac{1}{y} + \frac{1}{z}\right)$$

$$= 3 + \left(\frac{x}{y} + \frac{y}{x}\right) + \left(\frac{y}{z} + \frac{z}{y}\right) + \left(\frac{z}{x} + \frac{x}{z}\right)$$

$$(x-y)^2 \geq 0 \text{ implies } \frac{x}{y} + \frac{y}{x} \geq 2. \text{ So } f(x,y,z) \geq 9 \text{ and } f(1,1,1) = \boxed{9}$$

15. In how many different ways can \$100.00 be made from 5-cent, 10-cent, and 25-cent coins if it is required that exactly 1000 coins be used?

SOLUTION: Assume we have q quarters, d dimes and n nickels.

Then $q+d+n=1000$ and $25q+10d+5n=10000$, substituting $n=1000-q-d$ we have $20q+5d=5000$. So we have the $\boxed{251}$ solutions $q=0..250$; $d=1000-4q$, $n=3q$.