

HIGH-SPEED FLASH PHOTOGRAPHY FOR AMATEUR PHOTOGRAPHERS

Loren M. Winters

North Carolina School of Science and Mathematics, Durham, NC

This paper may be reproduced for non-commercial, educational purposes.

Contents

I. Introduction.....	1
II. Sound Triggers	2
A. Components	2
B. Piezoelectric trigger	2
C. Tape recorder trigger	3
D. Synchronization.....	4
III. Photogate and contact triggers and a delay unit.....	4
A. Photogate trigger.....	4
B. Delay circuit	5
C. Contact trigger	6
IV. Taking Photographs	6
A. The flash unit.....	6
B. The camera	7
V. Resources	7

I. Introduction

Electronic flash can be used to take sharp photographs of events occurring at high speed. Most flash units designed for amateur photographers can provide flashes of light as short as 30 millionths of a second. This is sufficient to "stop" such events as the impact of a tennis ball with a racket, a foot with a football, and the burst of a balloon or a popcorn kernel. The main problem to solve in taking photographs of these events--or simply in using electronic flash to view them directly--is to trigger the flash discharge when the event is occurring. Three types of triggers will be described. The simplest one, a metallic switch, closes automatically when the event occurs. Two other types detect sound or light from the event, convert the detected signal to a voltage pulse, and use it to electronically close the terminals of a flash unit.

The use of circuit diagrams throughout this paper assumes that the reader is familiar with basic electronics.¹ Kits containing parts for sound and photogate triggers and delay units are available from the sources given in Section V.

¹ A guide for those wishing to learn basic electronics is the Radio Shack publication, *Getting Started in Electronics*.

II. Sound Triggers

A. Components

The three parts of a sound trigger are the micro-phon, the amplifier, and a silicon-controlled rectifier (SCR). The diagram to the right shows how the components are connected. The microphone picks up the sound of the event to be observed. The signal from the microphone is then amplified in order to gate the SCR, which acts as a switch. The amplifier output is connected to the gate and cathode of the SCR, and the flash terminals are connected to the anode and cathode. When a sound is picked up by the microphone, the amplified electrical current flows in the gate-cathode circuit of the SCR. That in turn allows current to flow in the anode-cathode circuit, thus discharging the flash unit.

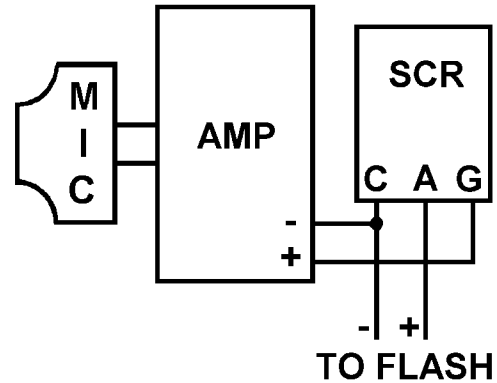

The SCR has a second function. It serves to isolate the amplifier from the voltage across the terminals of the flash unit. This can be as high as 330 V for older flash units. Newer units, however, may have low-voltage trigger circuits. In any case, an SCR rated for 400 V is sufficient.

B. Piezoelectric trigger

Sound triggers are convenient to use in many situations. If the event to be photographed produces a loud, sharp sound, piezoelectric triggers work fine. The pressure of the sound pulse on a piece of piezoelectric film distorts the film, which produces a voltage pulse in response. A transistor switch serves to gate a sensitive SCR, that is, one with a low gate current threshold.

While one can spend more than a hundred dollars for a professional model sound trigger, there are inexpensive alternatives that work just as well in many situations. The circuit shown here can be put together for less than \$10. It consists of a piezoelectric microphone,² a general-purpose transistor, a 5-k Ω variable resistor for sensitivity control, a 400-V SCR,³ and a 9-V source. The SCR must be sensitive to 0.2 ma of gate current or less.

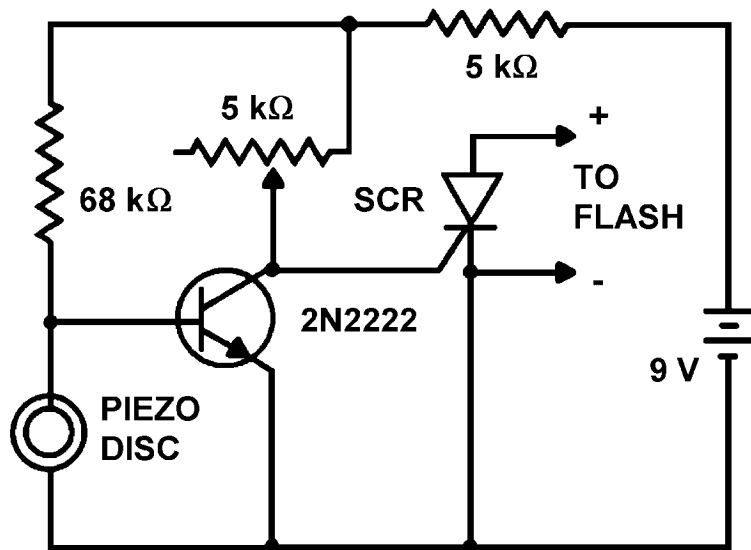

² One possible source is Radio Shack's piezoelectric buzzer element, part no. 273-064.

³ A source for a sensitive SCR is Digi-Key, 701 Brooks Ave. South, Box 677, Thief River Falls, MN 56701-0977, part # EC103D.

C. Tape recorder trigger

An audio amplifier with a dynamic or condenser microphone may be used to provide a sensitive sound trigger with a wide frequency response. The output current is great enough to gate a less sensitive SCR, such as the 400-V SCR available from Radio Shack (part no. 276-1020). An amplifier intended for sound reproduction will also work as a sound trigger. A microphone is used for the input, and a speaker or earphone output is used to gate an SCR to which the flash terminals are connected.

A tape recorder with a built-in microphone is particularly convenient to use. The recorder must be one that gives an output signal while recording. The only part that must be specially-constructed is the cord that connects the tape recorder to the flash unit. Two leads from the earphone jack are soldered to the gate and cathode of an SCR. The two leads from the flash terminals are connected to the cathode and anode. A method of making connections without having to cut the PC cord is described next.

1) Cut a 1-cm section from the top of a plastic ball-point pen cartridge. Insert this inside the collar of the connector at the end of the PC cord. If the plastic doesn't fit, shave or file off a little. The fit has to be snug to prevent the plastic from falling out. It serves as the insulation between the inner positive pin and the outer negative collar. A cross-sectional view of the assembly is shown to the right.

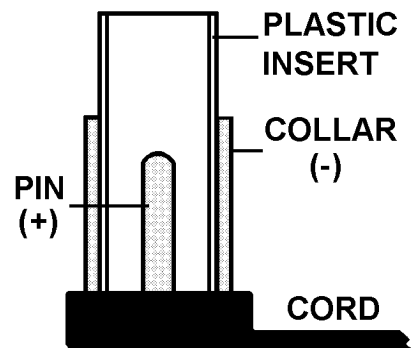

2) Clip the earphone off the earphone cable of the tape recorder. The leads that come from the recorder are the ones that will be used. They should be several feet long to allow the recorder to be positioned far from the flash. If they're too short, splice extra wire onto them. Strip a quarter of an inch of insulation from the ends of the leads. Then wrap one lead (either one) around the gate of the SCR and the other around the cathode. Solder or tape them in place.

3) Carefully bend the cathode of the SCR closer to the anode. Bend the gate farther from the anode. Then push the anode into the plastic sleeve inside the collar of the PC terminal. Be sure that the anode is pushed in far enough to make contact with the pin. Also check that the cathode is making contact on the outside of the collar. You may need to use tape to hold the cathode firmly in place. A photograph of the completed assembly is shown to the right.



When using the tape recorder sound trigger, insert a blank tape and turn on the record function. You'll probably find that the trigger is so sensitive that the click of the camera shutter may trigger the flash discharge prematurely, giving unwanted film exposures. In order to avoid this, hold your hand over the camera lens while opening the shutter.

One thing to try with this sound trigger is capturing the collision between a tennis ball and the racket. Hit the ball into a hanging sheet to prevent the ball from rebounding from walls.

D. Synchronization

When using a sound trigger, several factors influence the time delay between the high-speed event and the discharge of the flash. These include the intensity of the sound, the sensitivity of the trigger, and the position of the trigger in relation to the event. Changing the latter is a good way to fine tune the time delay, since one can use the fact that sound travels about 345 m/s in air. (A convenient way to remember this is as a third of a meter per millisecond.)

The initial placement of the sound trigger is a matter of guesswork. If it is placed close to the subject and the flash discharges sooner than desired, the trigger can simply be moved farther away. Photographs need not be taken as these adjustments are made, because naked-eye observations are possible.

The fact that the delay between the production of the sound and the discharge of the flash depends directly on the distance between the source of the sound and the microphone can be exploited to photograph the event at different times. For example, with the sound trigger next to a balloon, one can catch a rip in the balloon just as it is beginning. As the trigger is moved farther away, the rip will also have moved farther. With two flash units, independently triggered at different times during the event, double-exposure photographs can be made to show the progression of the event.

III. Photogate and contact triggers and a delay unit

A. Photogate trigger

A photogate, shown to the right, consists of an emitter and detector of light aimed at each other. The interruption of the beam of light from emitter to detector serves as the triggering event. The emitter may be a light-emitting diode (LED), a laser, or a beam of white light from, say, a penlight. The detector is a phototransistor, serving as a variable resistor whose resistance depends on the intensity of detected light.

The circuit shown uses an infrared emitter (XC-880-A) and detector (TIL414). A 2N2222 transistor acts as a switch in the gate-cathode path of an SCR. A sensitive-gate SCR is used. (See Footnote 3.) The SCR is connected either to the terminals of a flash unit or to a delay unit (to be described later). As long as the phototransistor is illuminated by the LED, the collector-emitter path of the 2N2222 is open. When the light is blocked, the voltage across the phototransistor rises and the 2N2222 conducts, thereby gating the SCR.

The sensitivity of the photogate is controlled with the 100-k Ω variable resistor. This is an important feature for detecting small, fast objects and allowing large separations between the detector and emitter. For maximum sensitivity, the resistance is adjusted low enough to raise the voltage across the phototransistor to the threshold of triggering. Whenever the detector-emitter separation is increased, the

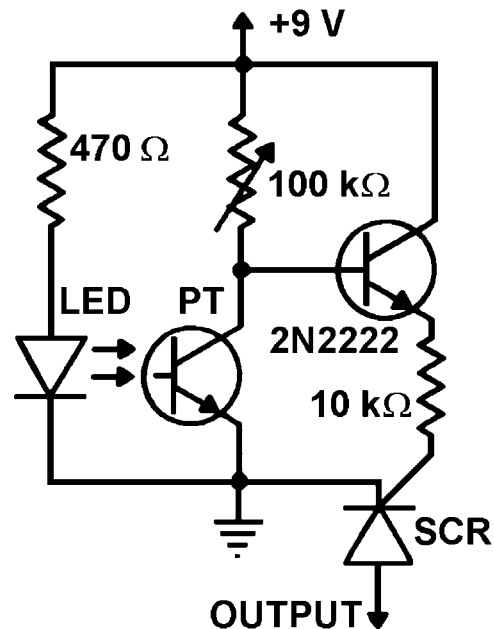

resistance must be increased, since the phototransistor's own resistance rises as the illumination on it decreases.

An interesting photograph to try with the photogate is the burst of a popcorn kernel. Aim the photogate across the top of a hot plate and just above the popcorn kernel. When the kernel pops, it will break the beam and set off a flash unit.

B. Delay circuit

An advantage that a photogate has over a sound trigger is that the former triggers on the precise location of the object that breaks the beam. For example, the shape of a snapped elastic cord can be photographed as it passes through the beam. While a sensitive sound trigger could also capture the shape, the location of the cord when the flash discharged would be much less predictable.

A complication when using a photogate occurs if the event to be photographed occurs after the breaking of the light beam. For example, if a liquid drop is to be photographed as it splashes into a pool of liquid, the photogate must be located above the pool. If the passage of the drop through the photogate were to be the event that triggered the flash unit, there would have to be a delay to allow the drop time to reach the pool. This difficulty can be overcome by using a delay circuit.

The delay circuit shown to the right uses a 556 timer, an IC consisting of two 555 timers. Grounding the input starts the first timer and produces a square pulse at output 1 (pin 5). The width of the pulse is determined by the choice of capacitance, C, and the setting of the 1-M Ω variable resistor. Output 1 is coupled to the trigger (pin 8) of the second timer through a 0.005- μ F capacitor. When output 1 falls to zero, the second timer starts, producing a 10-ms pulse at output 2 (pin 9). This pulse gates an SCR to discharge a flash unit. Output 1 can also be used to gate an SCR in order to provide an immediate flash discharge. The smallest time interval between the immediate and delayed discharges is about 0.2 ms.

When using the photogate and delay unit together, the output of the photogate becomes the input of the delay unit. The value of C chosen for the delay circuit depends on the experiment being conducted. If, for example, a drop of milk passes through the photogate and falls a distance of a half meter into a pool, a delay of about 0.3 s is required to capture the splash. Using a 0.5- μ F capacitor for C provides a selection of time intervals up to 0.5 s. (The time delay in seconds is approximately equal to the product of the variable resistance in megohms and C in microfarads.)

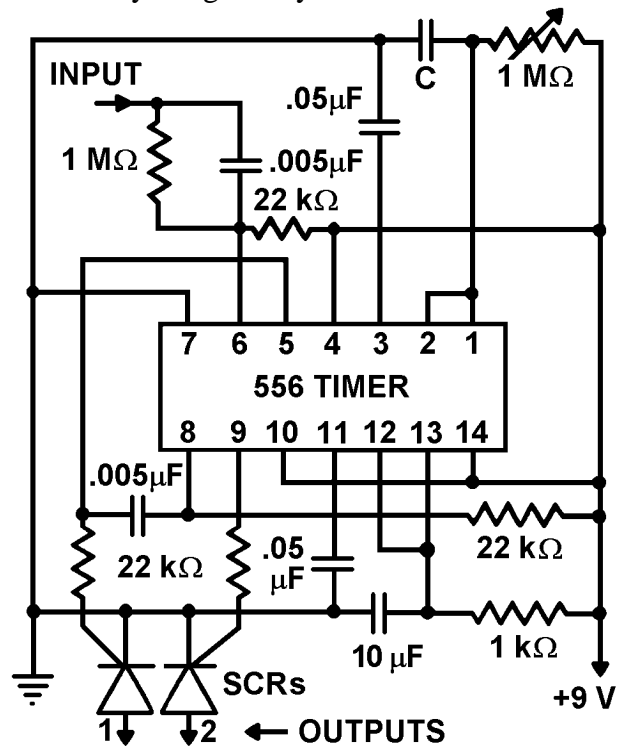

C. Contact trigger

The delay unit can also be used with a contact trigger. This is simply a metallic switch with leads connected to the input of the delay unit. When the switch is closed by, say, dropping a rubber ball on it, a flash unit will be discharged after the preset delay. By varying the delay, the collision can be observed in various stages.

A large area contact trigger that works well for dropped objects uses 2 20-cm squares of stiff cardboard, 2 20-cm squares of aluminum foil, and 1 20-cm square of black construction paper or poster board. Do the following to construct it. A diagram is shown below.

1) Smooth any wrinkles out of a 20-cm square of Al foil. Then glue the foil to the same size cardboard. Tape the bare end of a 1-m wire lead to one corner of the foil.

2) Smooth out another 20-cm square of foil and glue it to black construction paper of the same size. Tape another 1-m wire lead to a corner of this foil.

3) Cut out a 15-cm square hole from the second square of cardboard, leaving a square frame of 2.5-cm width. Glue this frame onto the foil prepared in step 2.

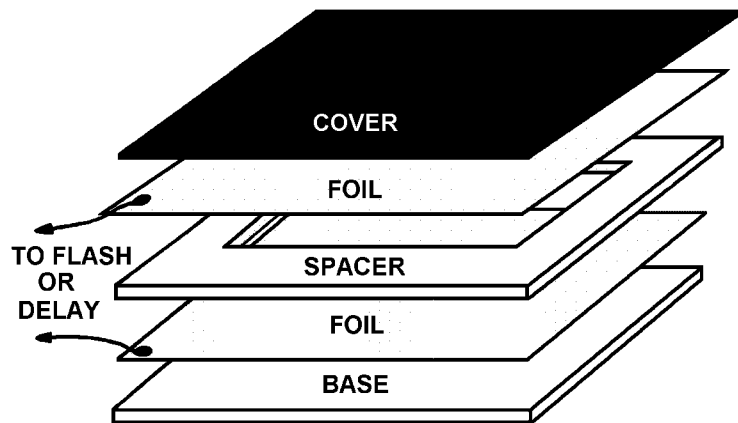

4) Arrange the pieces as shown in the diagram. The cardboard frame acts as a spacer to separate the pieces of foil. When an object is dropped onto the upper piece, it is forced into contact with the lower.

Something interesting to try with the contact trigger is to drop a squish ball or water balloon onto the trigger. If using a water balloon, protect the trigger with plastic. Vary the delay to capture the collision in various stages. One problem that may arise is that the flash unit discharges repeatedly on consecutive bounces. This can be prevented by replacing the 1-k Ω resistor of the delay circuit with a 100-k Ω or larger resistor.

IV. Taking Photographs

A. The flash unit

When an electronic flash unit discharges in its manual mode, the flash of light lasts for several milliseconds, much too long for "stopping" high-speed events. But when used in automatic mode, the flash of light can be terminated after a much shorter time. A photocell on the flash unit detects the light reflected from the subject and actuates a quenching circuit when sufficient light has been received for correct exposure. In this mode, durations as short as 30 millionths of a second can be achieved for many flash units.

In order to obtain such short durations, the flash unit must be set for automatic exposure and placed as close to the subject as convenient. If there are several automatic settings on the flash unit, the setting designated for the largest aperture (smallest f-stop) should be used.

On some flash units (the Vivitar 283, for example), the photocell is housed in a removable module. In such cases, it may be possible to replace the photocell with a variable resistor to allow predictable control of flash duration. (See Reference 1 in Section V.)

Most flash units are suitable for high-speed photography. If the unit has a PC cord, this will simplify the electrical connections. When the terminals of the PC cord are short-circuited, the flash discharges. If the unit has its terminals on the flash foot only, connections may have to be made there. Flash units dedicated to particular cameras will have several contacts on the flash foot. Typically, the center contact is the positive terminal of the flash trigger circuit, and the contact on the side of the foot is the negative terminal. An alternative to making connections directly to the flash foot is to use a device called a hot shoe adapter which has a PC cord attached to a hot shoe. These are available at some camera stores.

B. The camera

The camera used for high-speed photography need not have the capability for high shutter speeds, because the duration of the exposure is determined by the flash rather than the shutter. In fact, the camera shutter is held open (in the dark) before the flash discharges. This means that the camera must have a B setting. The lens should have manual focusing and an adjustable aperture. The selection of the aperture is determined by the automatic exposure setting used on the flash. A medium speed film such as ISO 400 is satisfactory. The higher the film speed, the smaller the lens aperture can be, thus providing greater depth-of-field.

Photographs are usually made in a darkened room. It is a good idea to have a featureless background to avoid interference with the subject. However, the background should not be placed too close to the subject. In the latter case, even a black background can produce undesirable glare or shadows.

With flash, camera, and trigger positioned as desired, the shutter of the camera is held open on the B setting in readiness for the discharge of the flash. After the discharge, the shutter is released and the room lights turned on.

V. Resources

For more information on high-speed flash photography, see the following articles by the author:

1. "High-Speed Photography with Sound Triggers," *The Physics Teacher* **28**, 12 (1990).
2. "A Photogate Flash Trigger and a Demonstration of Inertia", *The Physics Teacher* **30**, 411 (1992).
3. "A Visual Measurement of the Speed of Sound for Classroom Demonstration", *The Physics Teacher* **31**, 284 (1993).
4. "High-Speed Photography with Computer Control", *The Physics Teacher* **29**, 356 (1991).

For examples of high-speed photographs, see the following books:

5. Harold E. Edgerton and James R. Killian, Jr., *Moments of Vision: The Stroboscopic Revolution in Photography* (The MIT Press, Cambridge, MA, 1985).
6. Estelle Jussim and Gus Kayafas, *Stopping Time*, (Abrams, New York, 1987).

7. Stephen Dalton, *Split Second*, (Salem House, Salem, NH, 1984).

For more information on electronic flash, see the following books:

8. James Bailey, *How to select and use Electronic Flash* (HP Books, Tucson, AZ, 1983).

9. Lester Lefkowitz, *The Kodak Workshop Series: Electronic Flash*, (Eastman Kodak, Rochester, 1986).

10. Harold E. Edgerton, *Electronic Flash, Strobe* (The MIT Press, Cambridge, MA, 1983).

For a manual of activities in high-speed photography and for kits to build sound and photogate triggers and delay units, see this web site: <http://www.hiviz.com>.